

Experimental redesign of the castor bracket system

Ramon Lapurga

K00272822



Aim of the Project

The Aim of the project is to complete an improved concept for a bracket design from the group project. The bracket must be strong enough to support the FANUC RoboDrill, A two tonne Machine.

Background

Castor is a wheel that can rotate 360 degrees, used for transportation of a vehicle (object loaded onto a castor). The bracket is loaded onto the castor and takes the weight of the vehicles. It must be designed to withstand over 2 tonne of weight, and it must be easily operated to be perfect bracket. It contains holes for screws and/or bolts allowing a secure connection between the vehicle and the bracket and between the bracket and wheel.



Photo of : Castor wheel

Design of the bracket

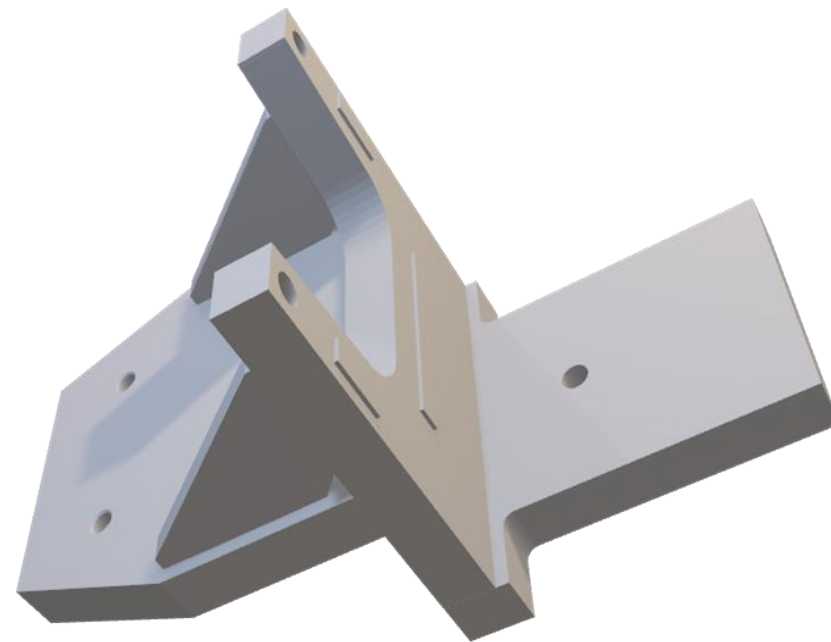

Figure 1: Design of the Bracket

As you can see this is the design of the bracket. This is the bracket we have well designed. We have given a design from FANUC themselves that is like the one on top. As it didn't give us an easy way to manufacture it, so we decided to find a way to assemble it the easy way. By making joints from the bottom, top and sides. The four holes at the top is where the castor wheel fits at the bottom. At the bottom part is where the hole for bolt connected to the stands. As we are going to replace them with our bracket. At the bottom is where we put it at stands and fit the bolt at the hole both CNC and bracket.

Improved design of the bracket

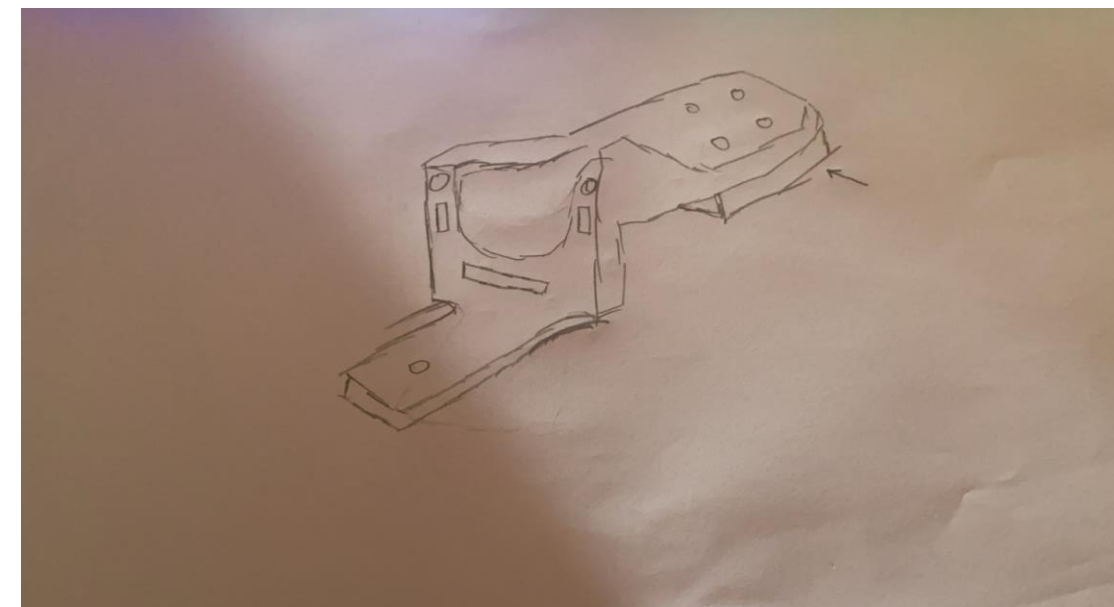

Photo of: improved bracket

For this improved design there were some design flows from last semester. The wheel from the would not spin around 360 degrees. So instead of a redesign of the bracket a plate installed below where the castor gets installed. The plate would be welded and the castor wheel can have full rotation while moving around

Photo of: plate for the improved bracket

Manufacturing Process

To manufacture these pieces, we decided to use a water jet cutter. Water Jet Cutting uses a high-pressure thin stream of water to cut through a material. The stream is often combined with an abrasive material/s to aid in cutting through materials. To assemble the parts welding was one of the processes used in this project.

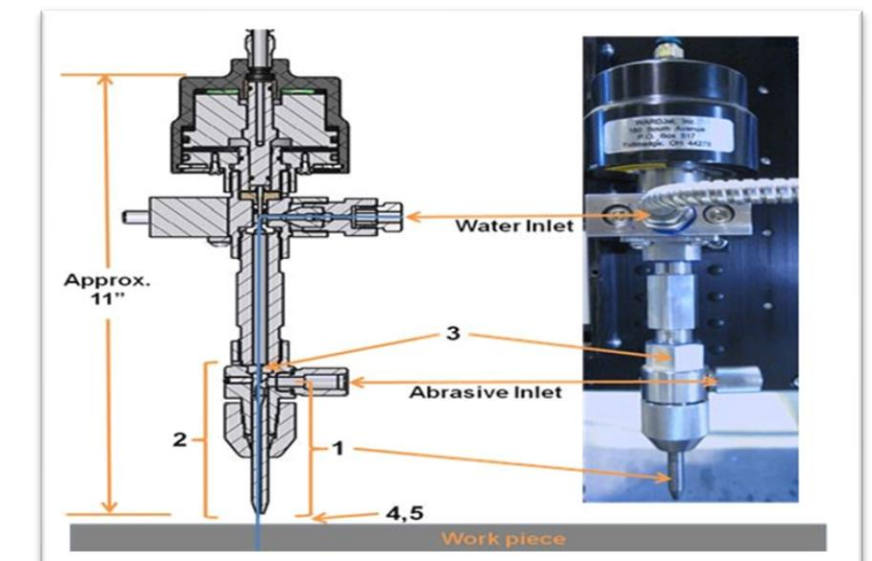

Conclusion

- The bracket was redesigned
- For all the research for every topic the final design was seen to be an exactly fully working castor
- Still used the same castor as last semester

References

<https://ie.rs-online.com/web/p/castor-wheels/6114414>